

Safety

- Do not cover the ground contact.
- Do not place any material near the luminaire. Ensure a minimum distance of 0.5M.
- Do not insert objects into the luminaire.
- Do not clean using any solvent based abrasive or aggressive product.
- Do not pull any cables connected to the product.
- Do not direct the luminaire into a persons eyes, as this unit may have an intense light output, which if incorrectly used may cause eye damage.
- Light engines/LED'S and other light sources may heat up, please take care when handling the products.
- The manufacturer will not be deemed liable or held responsible for any damages caused by faults or manufacturing defects that may be present in any of its products or the misuse or incorrect installation of this device. Please refer to our trouble shooting guide for further information.
- The manufacturer will not be held liable for any death(s) or injuries caused by misuse or poor installation or any unreported faults of this product version or versions thereof.
- LED's are sensitive to electrostatic discharge. Do not touch the surface of the LED module.
- Do not connect to a temporary electricity supply, this may damage the electronics.
- Light fittings with an integrated emergency option are with a separate installation and wiring leaflet. Please refer to this manual for further details. If the manual is unavailable please contact an ALL LED representative for assistance.

Returns & Faulty Items

- If any problem is encountered during or after installation, please call ALL LED technical department to get the problem resolved ASAP.
- Please do not just return the item to the outlet you purchased it from, as you are only entitled to a replacement or refund after the unit has undergone testing and the unit has been confirmed as having a manufacturing defect/fault. Your statutory rights are not affected.
- The manufacturer will not be deemed liable or held responsible for any damages caused by faults or manufacturing defects that may be present in any of its products or the misuse or incorrect installation of this device. Please refer to our trouble shooting guide for further information.
- All installations must be carried out in accordance with this installation guide and user manual.
- All goods are supplied under the terms and conditions of ALL LED LTD, a copy of which may be obtained upon written request.



Environmental Protection
Waste electrical products should not be disposed of with household waste. Please recycle where facilities exist. Check with your Local Authority or retailer for recycling advice



This product supplied with a limited 3 year guarantee, subject to terms and conditions. The manufacturer will not be deemed liable or held responsible for any damages caused by faults or manufacturing defects that may be present in any of its products or the misuse or incorrect installation of this device. Your statutory rights are not affected.

ALL LED LTD
Unit D1 Braintree Industrial Estate
Braintree Road
Ruislip
HA4 0EJ

www.allledgroup.com
sales@allledgroup.com
Tel: +44 (0)208 841 9000



INSTALLATION GUIDE & USER MANUAL ASC/WIFI/APP/GATE



ENSURE POWER SUPPLY IS OFF WHEN HANDLING ANY ELECTRICAL EQUIPMENT.

- This product may need to be installed by a qualified electrical installer.
- Please read this guide in its entirety to fully understand the products before attempting any install.
- All electrical work should be completed in accordance with the latest IET regulations, and/or any other relevant rules, regulations or laws of the country in which it is being installed.
- The item must be installed in isolation from any insulating material and is adequately ventilated to prevent premature failure.
- Ensure power supply is isolated prior to installation, maintenance or performing any other form of electrical work.
- The company MUST be contacted immediately for advice or swift resolution of any matters concerning any of ALL LED's products.

Technical Specifications

PRODUCT CODE	ASC/WIFI/APP/GATE
Operation voltage	220-240V AC (Adapter)
Operation Frequency	868MHz

Dimensions (mm)

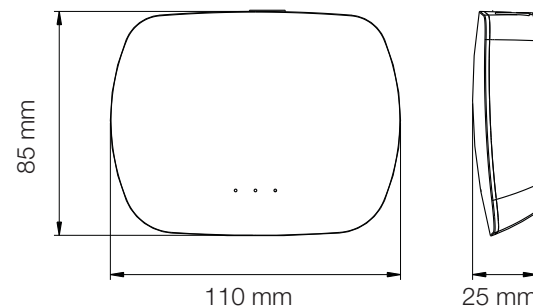

Trouble Shooting Guide

Installation Method

Select a location central to receivers.

Method 1:

Plugging gateway directly into router.

Easy & Quick Method

Plug the ethernet cable (supplied) into the gateway and router, then plug in the gateway to the electrical outlet using the adapter supplied.

Wait 30s for the unit to boot.

Download the All LED App by searching for 'ALL LED' in the app store or play store. Android and IOS compatible.

Open app If any errors show on the app, hard close it and reopen it. If there are no errors, the gateway has been added to the network successfully. Please proceed to Programming section below.

Please proceed to Programming section below.

Method 2:

Connecting gateway to home network wirelessly (Requires More Steps)

Plug the gateway into the electrical outlet using the adapter supplied. Wait 30s to boot and then use your phone to search for wireless networks.

Connect your Mobile Device through WIFI to the **EASYLIGHTING** network using password **0123456789**. Your device may prompt 'This WIFI network has no internet access.' Select Connect anyway if the option appears. Open the All LED App, and **select settings** on the **bottom panel**. Click the **top left square** labelled '**Connect WIFI LED.....Home Network**'.

A prompt may appear asking if your phone is connected to the gateway, press **YES**.

Please wait for the gateway to search for networks. When your home network is displayed please select it and enter the network password.

Then close the app (hard close) and reopen it, ensuring you are now connected to your home network.

Please proceed to Programming section below.

Programming:

Ensure when you open the app you do not get an error message. If you do, please hard close the app and reopen it. Press 'Room' and ensure only one zone is selected at a time when programming. The zone selected is indicated by the small green tick. Press room again to display the colour wheel.

Press the learning Key on the receiver like a mouse click (to put in learning mode) and then spin the colour wheel. The strip should flash to acknowledge successful pairing.

If any problem is encountered during or after installation, please call us on 0208 841 9000

PROBLEM	CAUSE(S)	SOLUTION(S)
No Light Output From LED's	No power to drive components	A qualified installer/electrician should check the Primary voltage side of the product to check the input voltage.
	Loose connection on circuit	Ensure continuous and correct connection between terminals.
	Incorrect Polarity	Check the black and red cables on the circuit, + and - respectively are correctly connected to the correct terminals.
	No output from the driver	Driver may be faulty and require replacement.
	Overvoltage may have caused damage to the sensitive components	These cases are rare and the item may need replacement and/or investigation as to the cause of failure.
	No Battery/End of battery life	Insert/Replace battery.
	Devices not paired	Pair devices using instructions.
LED's Flashing	Incorrect driver being used for the product	Please only use drivers designed for this product. Failure to do so will void the warranty.
	LED driver may be connected to a mains dimmer switch	Please remove the dimmer switch and wire the unit according to the wiring diagram on the opposite page, removing any mains dimmers or incompatible dimming on the primary side. Use of this product on a dimmer will void the warranty.
	Loose connection on circuit.	Ensure continuous and correct connection between the terminals.



ATTENTION

IF ANY PROBLEMS PERSIST, PLEASE CALL THE ALL LED TECHNICAL DEPARTMENT FOR FURTHER ASSISTANCE.