

Safety

- Do not cover the ground contact.
- Do not place any material over the lens or LED diode/chip.
- Do not insert objects into the luminaire.
- Do not clean using any solvent based abrasive or aggressive product.
- Do not pull any cables connected to the product.
- Do not direct the luminaire into a persons eyes, as this unit may have an intense light output, which if incorrectly used may cause eye damage.
- Light engines/LED'S and other light sources may heat up, please take care when handling the products.

The manufacturer will not be deemed liable or held responsible for any damages caused by faults or manufacturing defects that may be present in any of its products or the misuse or incorrect installation of this device. Please refer to our trouble shooting guide for further information.

The manufacturer will not be held liable for any death(s) or injuries caused by misuse or poor installation or any unreported faults of this product version or versions thereof. LED's are sensitive to electrostatic discharge. Do not touch the surface of the LED module. Do not connect to a temporary electricity supply, this may damage the electronics. Light fittings with an integrated emergency option are with a separate installation and wiring leaflet. Please refer to this manual for further details. If the manual is unavailable please contact an ALL LED representative for assistance.

Do not install in areas with; high acid rain, acidic soil, high salt content, coastal environments, high concentration of chemical substances.

LED drivers may hold some residue discharge that may cause damage to the LED components if the driver is not allowed to discharge in time. Please refer to the relevant power supply instructions for details.

Returns & Faulty Items

If any problem is encountered during or after installation, please call ALL LED technical department to get the problem resolved ASAP.

Please do not just return the item to the outlet you purchased it from, as you are only entitled to a replacement or refund after the unit has undergone testing and the unit has been confirmed as having a manufacturing defect/fault. Your statutory rights are not affected. The manufacturer will not be deemed liable or held responsible for any damages caused by faults or manufacturing defects that may be present in any of its products or the misuse or incorrect installation of this device. Please refer to our trouble shooting guide for further information.

All goods are supplied under the terms and conditions of ALL LED LTD, a copy of which may be obtained upon written request.

PLEASE ALLOW ADEQUATE TIME FOR DRIVERS TO DISCHARGE DO NOT CONNECT/DISCONNECT THE LUMINAIRES TO ANY DC CIRCUIT WHEN THERE IS ANY CURRENT/VOLTAGE OUTPUT ON THE DRIVER PLEASE REFER TO THE RELEVANT POWER SUPPLY INSTRUCTIONS FOR DETAILS.



This product supplied with a limited 5 year guarantee, subject to terms and conditions. The manufacturer will not be deemed liable or held responsible for any damages caused by faults or manufacturing defects that may be present in any of its products or the misuse or incorrect installation of this device. Your statutory rights are not affected.

ALL LED LTD
42 Sedgwick Road
Luton
Bedfordshire
LU4 9DT

www.allledgroup.com
sales@allledgroup.com
Tel: +44 (0)208 841 9000



INSTALLATION GUIDE AMKR020AL RANGES



OUTPUT LOOM REQUIRES SERIES WIRING

This product must be installed by a qualified electrical installer. All electrical work should be completed in accordance with the latest IET regulations, or any other relevant rules, regulations or laws of the country in which it is being installed. This item is suitable for humid environments when installed correctly and carries an ingress protection rating of IP65. Ensure the item is isolated from any form of insulation and is adequately ventilated to prevent premature decay of the LED package. Ensure power supply is isolated prior to installation, maintenance or performing any other form of electrical work. The company MUST be contacted immediately for advice or swift resolution of any matters concerning any of ALL LED's products. This product requires DC 350mA (series wiring) constant current to function properly.

Technical Specifications

Product Code	AMKR020AL/30	AMKR020AL/40	AMKR020AL/BL
Wattage	1W	1W	1W
Operating Current	350mA	350mA	350mA
CCT	3000K	4000K	BLUE
CRI	>80	>80	
Beam Angle	50°	50°	50°
Lifetime to LM70	50000h	50000h	50000h
Lumens	≤60	≤70	≤25
Switching Cycles	<100,000	<100,000	<100,000
Ambient Operating Temp	-20°~+50°C	-20°~+50°C	-20°~+50°C
SDCM	<6	<6	<6
Starting Time (Chip)	Instant Full Light	Instant Full Light	Instant Full Light
Ingress Protection	IP44	IP44	IP44
Overall Diameter	30 mm	30 mm	30 mm
Cutout Diameter	20 mm	20 mm	20 mm



PLEASE ALLOW ADEQUATE TIME FOR DRIVERS TO DISCHARGE DO NOT CONNECT/DISCONNECT THE LUMINAIRES TO ANY DC CIRCUIT WHEN THERE IS ANY CURRENT/VOLTAGE OUTPUT ON THE DRIVER PLEASE REFER TO THE RELEVANT POWER SUPPLY INSTRUCTIONS FOR DETAILS.

Environmental Protection
Waste electrical products should not be disposed of with household waste. Please recycle where facilities exist. Check with your Local Authority or retailer for recycling advice



Installation

We recommend checking the installation with the products for suitability prior to installation.
Turn off power supply at source to avoid any risk of electric shock.

Locate where the LED is to be installed
Cut the appropriate size hole according to the product. If installing in the ground, please use a 300mm thick layer of gravel with a diameter of 30cm to support drainage. Do not install this product into an area that is constantly wet or where water has a chance to pool. Drainage is an absolute requirement.

Connect the luminaires as shown in the SERIES WIRING DIAGRAM BELOW.

Connect the +/- to the LED driver (not incl.)

Connect the AC input of the LED driver to the relevant electrical circuit.

Double check the connections and the overall installation.

Turn the power supply on and check the item is functioning as it should

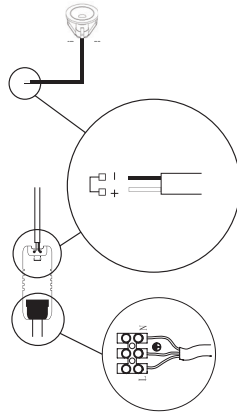

Series Wiring Diagram

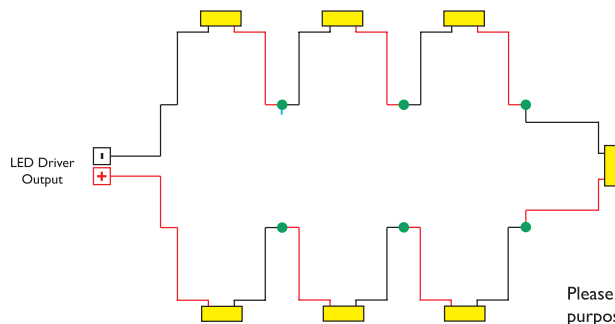

Please note this diagram is for indicative purposes only. Actual wiring may differ.

Dimensions (mm)

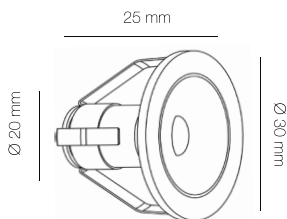

AMKR020AL
Cutout: 20 mm
Overall: 30 mm
Depth: 25 mm

Trouble Shooting Guide

PROBLEM	CAUSE(S)	SOLUTION(S)
No Light Output From LED's	No power to drive components.	A qualified installer/electrician should check the Primary voltage side of the product to check the input voltage.
	Loose connection on primary side.	Ensure continuous and correct connection between terminals.
	Loose or switched connection/polarity on secondary side.	Ensure continuous and correct connection between terminals. Ensure the polarity is correct; (Red = +, Black = -).
	No output from the driver.	No power entering LED driver. Driver may be faulty and require replacement following investigation.
	Over voltage may have caused damage to the sensitive LED drive components.	These cases are rare and the item may need replacement and/or investigation as to the cause of failure.
LED's Flashing	Unstable or incorrect input/output voltage/current.	Please only use a stable voltage supply as stipulated earlier for this product. Failure to do so will void the warranty.
	LED driver may be connected to an incompatible dimmer switch	Please remove the dimmer switch and replace with a compatible unit.
	Loose connection on primary side.	Ensure continuous and correct connection between the terminals.
	Loose connection on secondary side.	Ensure continuous and correct connection between terminals. Ensure the polarity is correct; (Red = +, Black = -).
	Wattage overload	Too much power is trying to be drawn from the item. Flashing indicates the overload protection is actively working to prevent any damage to the item. Reduce the load on the DC side of the item.



ATTENTION

IF ANY PROBLEMS PERSIST, PLEASE CALL THE ALL LED TECHNICAL DEPARTMENT FOR FURTHER ASSISTANCE.